

695MH SE

KNUCKLEBOOM LOADERS > STATIONARY MOUNTS

SCRAP



Introducing the Barko 695MH SE

Dependable. Exceptional. BEAUTIFUL. That's what customers say about the Barko 695MH SE. One of our largest and most powerful knuckleboom loader (material handler) also provides increased work productivity, and the lowest total cost of operation of any other product on the market.

It is BEAUTIFUL, but don't let that fool you. The power and swing torque of the 695MH SE makes it a BEAST capable of delivering up to 25% more loads every day. Equipped with more standard features than its competitors, the 695MH SE lasts longer, performs harder, and delivers the results you expect, all while providing more comfort. There's nothing better than a Barko – Guaranteed!

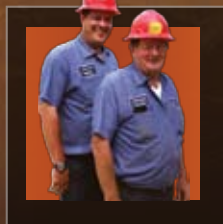

Visit our website at:
www.barko.com
to read customer testimonials

695



BARKO HYDRAULICS, LLC

One Banks Avenue | Superior, WI 54880 | Ph: 715.392.5641 | Fx: 715.392.3931

WWW.BARKO.COM

695MH SE

KNUCKLEBOOM LOADERS > STATIONARY MOUNTS

SCRAP

MAXIMUM LIFT CAPACITY

46' 0" (14.0 m) straight boom, less attachment.

Radius	Lift	
15' (4.57 m)	39,630 lbs.	(17,976 kg)
20' (6.10 m)	30,670 lbs.	(13,912 kg)
25' (7.62 m)	24,190 lbs.	(10,972 kg)
30' (9.14 m)	19,940 lbs.	(9,045 kg)
35' (10.67 m)	18,890 lbs.	(8,568 kg)
40' (12.19 m)	14,620 lbs.	(6,632 kg)
45' (13.72 m)	11,960 lbs.	(5,425 kg)

BOOM DATA

Boom	46' 0"	(14.0 m)
Main	29' 0"	(8.8 m)
Stick	17' 4"	(5.3 m)

Boom structure: All welded construction with fabricated box type design. Bronze bushings with grease grooves at boom pivot points.

BOOM REACH

Vertical height based on 40" (1016 mm) high pedestal.

	46' 0"	(14.0 m)
Horizontal	46' 5"	(14.12 m)
Vertical	48' 8"	(14.83 m)

CYLINDERS

Hydraulic cylinders with wear rings on pistons and bolt on glands for extended life.

All cylinders are made of heavy wall steel tubing. Induction hardened cylinder rods with heavy chrome plating.

Main boom: dual 6" x 47" (152 mm x 1194 mm) with 4" (102 mm) rod.

Stick boom: dual 6" x 41" (152 mm x 1041 mm) with (102 mm) rod.

Hose break protection valves.

ELECTRICAL SYSTEM

Drip-proof, fully encapsulated Lincoln electric motors: One 125 HP and one 75HP.

Both are 3-phase, 460 volt, 60 Hz and operate at 1800 RPM.

Electric Collector: Four pass, 300 amp capacity on each ring, mounted in pedestal base with continuous rotation only.

All enclosures are NEMA 4 rated.

Soft start on 125 HP motor with 3 phase monitor.

On/Off key switch with Start/Stop function on display panel.

E-Stop mounted on dash.

Ability to adjust max speed for boom and swing function on display panel.

HYDRAULIC SYSTEM

161 gallon (610 L) hydraulic oil reservoir with return line filter, shut off valve on pump suction line.

Main Pumps: two variable displacement piston pump producing 90 GPM (342 LPM).

Swing Pump: hydrostatic axial piston pump producing 36 GPM (135 LPM) at 3600 PSI (248 BAR).

Main system operating pressure: 4,350 PSI (300 BAR).

Heavy wall tubing and multi-wire braided hose throughout system

Quick disconnect diagnostic ports.

SWING SYSTEM

Continuous rotation on 54" (1372 mm) internal tooth turntable bearing.

Swing speed 7.1 RPM - Hydrostatic Power transmitted through piston motors and planetary gearboxes.

3,600 PSI (248 BAR) operating pressure. Swing torque: 55,000 ft. lbs. (74,570 Nm) (100% theoretical)

Tailswing: 10' 6" (3.19 m) with counterweight.

OPERATOR'S CAB

F.O.P.S. certified.

38-1/2" x 55" (978 mm x 1397 mm) forward sloping pressurized cab with sound suppression insulation.

Roof window, sliding side windows with tinted glass on all windows.

Pantograph windshield wipers, washer, and dome light.

Adjustable suspension style seat with arm rests. Dual joystick controls.

Dash console with cab accessory switches and start/stop controls all located for easy access. AM/FM CD radio.

Swing control operated by foot pedal.

Swing out door and front cab guard.

(6) 24 volt DC halogen cab lights, inside front guard.

Climate controlled heating and air conditioning.

Central turntable greasing system.

MISCELLANEOUS

Weight with standard equipment and oil: 46,000 lbs. (20,865 kg) (not including attachment).

Equipment greased and hydraulic tank filled.

Removable panels for serviceability

OPTIONS/ACCESSORIES

43' Live Heel Boom

51' Straight Boom

Boom Lights: 24 volt, DC.

Hand Swing

Rotation Stops (310 Degree Max)

575 Volt Electric System

Auxiliary Hydraulic Oil Cooler

Swing Brake

Automatic Grease System

Hydraulic Reservoir Heater: 3 kw

Magnet Rectifier Package

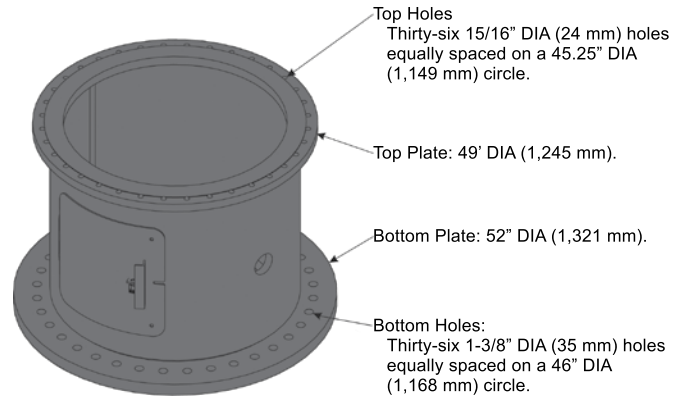
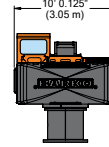
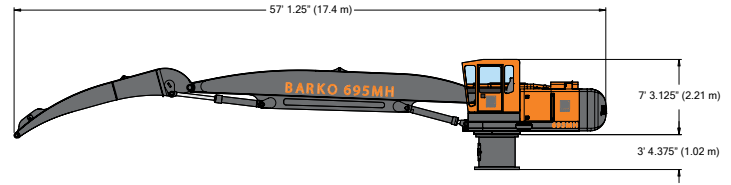

BARKO HYDRAULICS, LLC

One Banks Avenue | Superior, WI 54880 | Ph: 715.392.5641 | Fx: 715.392.3931 | www.barko.com