

595ML SE

KNUCKLEBOOM LOADERS > STATIONARY MOUNTS

INDUSTRIAL



Introducing the Barko 595ML SE

Dependable. Exceptional. BEAUTIFUL. That's what customers say about the Barko 595ML SE. One of our largest and most powerful knuckleboom loader (material handler) also provides increased work productivity, and the lowest total cost of operation than any other product on the market.

It is BEAUTIFUL, but don't let that fool you. The power and swing torque of the 595ML SE makes it a BEAST capable of delivering up to 25% more loads every day. Equipped with more standard features than its competitors, the 595ML SE lasts longer, performs harder, and delivers the results you expect, all while providing more comfort. There's nothing better than a Barko – Guaranteed!



Visit our website at:
www.barko.com
to read customer testimonials



BARKO HYDRAULICS, LLC

One Banks Avenue | Superior, WI 54880 | Ph: 715.392.5641 | Fx: 715.392.3931

WWW.BARKO.COM

595ML SE

KNUCKLEBOOM LOADERS > STATIONARY MOUNTS

INDUSTRIAL

MAXIMUM LIFT CAPACITY

32' 0" (9.75 m) straight boom, less attachment.

Radius	Lift	
12' (3.65 m)	38,180 lbs.	(17,318 kg)
15' (4.57 m)	30,290 lbs.	(13,739 kg)
20' (6.10 m)	22,580 lbs.	(10,242 kg)
25' (7.62 m)	17,990 lbs.	(8,141 kg)
30' (9.14 m)	12,810 lbs.	(5,810 kg)
32' (9.75 m)	7,770 lbs.	(3,524 kg)

BOOM DATA

Main	32' 0"	(9.75 m)
Stick	18' 6"	(5.64 m)
Stick	13' 10"	(4.22 m)

Boom structure: All welded construction with fabricated box type design. Aluminum bronze bushings with grease grooves at boom pivot points.

BOOM REACH

Vertical height based on 33" (838 mm) high pedestal.

	32' 0"	(9.75 m)
Horizontal	32' 0"	(9.75 m)
Vertical	37' 7"	(11.45 m)

CYLINDERS

Hydraulic cylinders with wear rings on pistons and bolt on glands for extended life. All cylinders are made of heavy wall steel tubing. Induction hardened cylinder rods with heavy chrome plating.

Main boom: 7" x 51" (178 mm x 1295 mm) with 4" (102 mm) rod.

Stick boom: 7" x 35" (178 mm x 889 mm) with 102 mm rod.

Spherical bearings at all boom cylinder pivots.

AVAILABLE POWER SOURCES

Drip-proof encapsulated electric motor, 125 HP, 3-phase, 460 volt, 60 Hz, operates at 1800 RPM.

Electric collector: 4-pass, 300 amp capacity on each ring, mounted in pedestal base with continuous rotation only.

Electrical package: Breaker, NEMA 4 enclosure with motor start circuit and 3 phase power monitor.

Key start switch and emergency stop switch mounted on control console.

HYDRAULIC SYSTEM

120 gallon (454 L) hydraulic oil reservoir with return line filter, shut off valve on pump suction line.

Pump: Variable displacement piston pump producing 119 GPM (450 LPM).

Heavy wall tubing and multi-wire braided hose throughout system.

Main system operating pressure 3600 PSI (248 BAR).

Quick disconnect diagnostic ports.

SWING SYSTEM

Continuous rotation on 54" (1372 mm) internal tooth turntable bearing.

Swing speed 7.5 RPM - Power transmitted through piston motors and planetary gearboxes.

3,600 PSI (248 BAR) operating pressure.

Swing torque: 55,000 ft. lbs. (74,570 Nm) (100% theoretical)

Tailswing: 8' 5 1/2" (2.57 m) without counter weight.
8' 6 1/2" (2.60 m) with optional counterweight.

OPERATOR'S CAB

F.O.P.S. certified.

38-1/2" x 55" (978 mm x 1397 mm) forward sloping pressurized cab with sound suppression insulation.

Roof window, sliding side windows with tinted glass on all windows.

Pantograph windshield wipers, washer, and dome light.

Adjustable suspension style seat with arm rests. Dual joystick controls.

Dash console with cab accessory switches and start/stop controls all located for easy access. AM/FM CD radio.

Swing control operated by foot pedal.

Swing out door and front cab guard.

(6) 12 volt DC halogen cab lights, inside front guard.

Climate controlled heating and air conditioning.

Central turntable greasing system.

MISCELLANEOUS

Weight with standard equipment and oil: 29,000 lbs. (13,154 kg) (not including attachment).

Equipment greased and hydraulic tank filled.

Removable panels for serviceability

OPTIONS/ACCESSORIES

32' Live Heel Boom

36' Straight Boom

36' Live Heel Boom

40' Straight Boom

36' Coil Handler Boom

Boom Lights: 12 volt, DC.

3000 lb. (1360 kg) Cast steel counter weight.

7000 lb. (3175 kg) Cast steel counter weight.

9975 lb. (4524 kg) Cast steel counter weight.

Standard detachable heel bar

Log & Pulp Grapples

Grapple Saw

Servo Controlled Hand Swing

Rotation Stops (310 Degree Max)

575 Volt Electric System

Auxiliary Hydraulic Oil Cooler

23" Hydraulic Tilt Cab Riser

42" Fixed Cab Riser

42" Hydraulic Tilt Cab Riser

Swing Brake

12V Hydraulic Transfer Pump

Automatic Grease System

Hydraulic Reservoir Heater: 3 kw

Magnet Rectifier Package

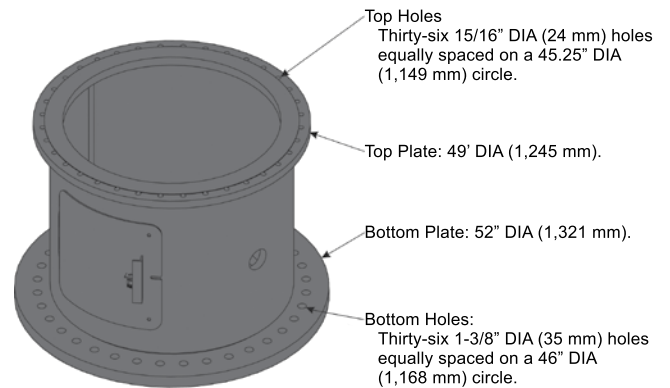
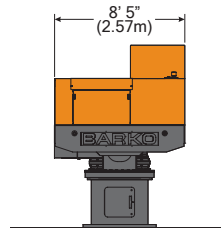
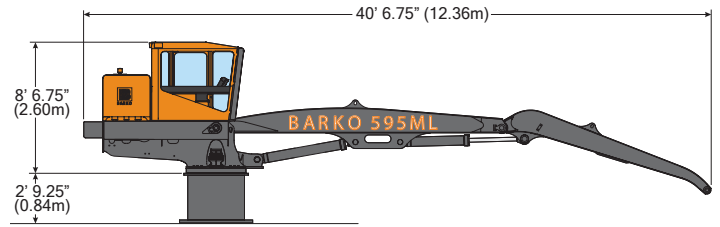

BARKO HYDRAULICS, LLC

One Banks Avenue | Superior, WI 54880 | Ph: 715.392.5641 | Fx: 715.392.3931 | www.barko.com