

# 495ML SE ERS

KNUCKLEBOOM LOADERS > STATIONARY MOUNTS

INDUSTRIAL

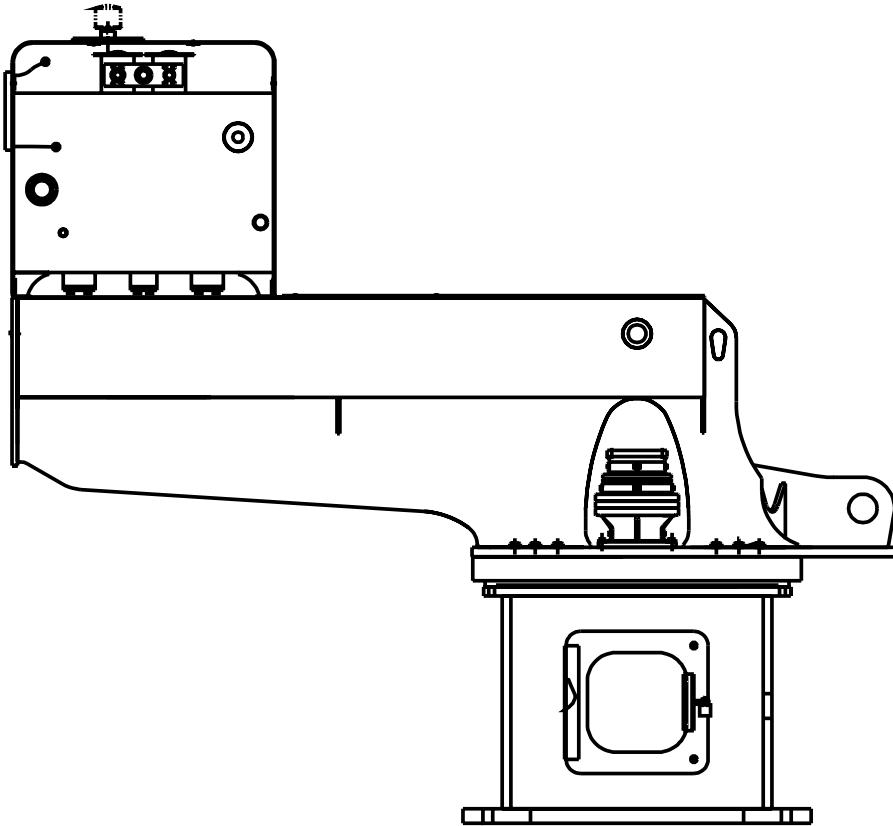

## Introducing the Barko 495ML SE ERS

The Barko 495ML SE-ERS is our 495ML SE (stationary electric) with an ERS (electric remote station) instead of a cab.

Offering more power than the 295ML SE-ERS, the 495ML SE-ERS provides increased work productivity. And like all Barko stationary electric knuckleboom loaders (material handlers), the 495ML SE-ERS provides the lowest total cost of ownership than any other product in its' class.

Snatch more and load it with effortless speed and ease. The power and swing torque of the Barko 495ML SE-ERS makes it capable of delivering up to 25% more loads every day. Equipped with more standard features than its competitors, the 495ML SE-ERS lasts longer, performs harder, and delivers the results you expect. Nothing performs like a Barko. And once you buy one, you'll never want anything else!

# 495

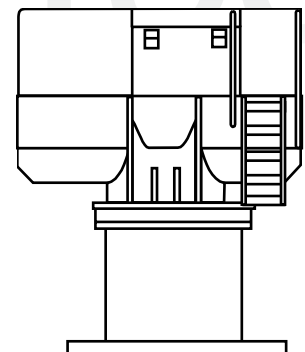

WWW.BARKO.COM



Visit our website at:  
[www.barko.com](http://www.barko.com)  
to read customer testimonials



**BARKO** HYDRAULICS, LLC

One Banks Avenue | Superior, WI 54880 | Ph: 715.392.5641 | Fx: 715.392.3931

# 495ML SE ERS

KNUCKLEBOOM LOADERS > STATIONARY MOUNTS

INDUSTRIAL

## MAXIMUM LIFT CAPACITY

32' 0" (9.75 m) straight boom, less attachment.

Radius	Lift	
12 (3.65 m)	27,720 lbs.	(12,574 kg)
15' (4.57 m)	21,960 lbs.	(9,961 kg)
20' (6.10 m)	16,350 lbs.	(7,416 kg)
25' (7.62 m)	12,990 lbs.	(5,892 kg)
30' (9.14 m)	9,280 lbs.	(4,209 kg)
32' (9.75 m)	5,590 lbs.	(2,535 kg)

## BOOM DATA

Main	32' 0"	(9.75 m)
Stick	18' 6"	(5.64 m)
Stick	13' 10"	(4.22 m)

Boom structure: All welded construction with fabricated box type design. Aluminum bronze bushings with grease grooves at boom pivot points.

## BOOM REACH

Vertical height based on 33" (8.38 mm) high pedestal.		
32' 0"	(9.75 m)	
Horizontal	32' 0"	(9.75 m)
Vertical	37' 7"	(11.45 m)

## CYLINDERS

Hydraulic cylinders with wear rings on pistons and bolt on glands for extended life. All cylinders are made of heavy wall steel tubing. Induction hardened cylinder rods with heavy chrome plating.

Main boom: 6" x 51" (152mm x 1295mm) with 3-1/2" (89mm) rod.  
Stick boom: 6" x 35" (152 mm x 889 mm) with 3-1/2" (89 mm) rod.  
Spherical bearings at all boom cylinder pivots.

## AVAILABLE POWER SOURCES

Drip-proof encapsulated electric motor, 100 HP, 3-phase, 460 volt, 60 Hz, operates at 1800 RPM.  
Electric collector: 4-pass, 300 amp capacity on each ring, mounted in pedestal base with continuous rotation only.  
Electrical package: Breaker, NEMA 4 enclosure with motor start circuit and 3 phase power monitor.  
Key start switch and emergency stop switch mounted on control console.

## HYDRAULIC SYSTEM

120 gallon (454 L) hydraulic oil reservoir with return line filter, shut off valve on pump suction line.  
Pumps: Variable displacement piston pump producing 88 GPM (333 LPM).  
Heavy wall tubing and multi-wire braided hose throughout system.  
Main system operating pressure 3600 PSI (248 BAR).  
Quick disconnect diagnostic ports.

## SWING SYSTEM

Continuous rotation on 46" (1168 mm) internal tooth turntable bearing.  
Swing speed 9 RPM - Power transmitted through dual piston motors and planetary gearboxes.  
3,600 PSI (248 BAR) operating pressure.  
Swing torque: 44,000 ft. lbs. (59,656 Nm) (100% theoretical).  
Tailswing: 8' 5 1/2" (2.57 m) without counterweight.  
8' 6 1/2" (2.60 m) with optional counterweight.

## MISCELLANEOUS

Weight with standard equipment and oil: 26,000 lbs. (11,793 kg) (not including attachment).  
Equipment greased and hydraulic tank filled.  
Removable panels for serviceability.

## OPTIONS/ACCESSORIES

Detachable heel bar.  
Servo controlled hand swing.  
Carrier slasher delimeter package.  
Circle saw slasher package.  
32' 0" live heel boom.  
12 volt DC boom lights.  
Hydraulic reservoir heater: 5 kw.  
Auxiliary electric collector packages.  
575 volt electrical system.  
3,000 # counterweight.  
1,300 # counterweight.  
Log & pulpwood grapples.

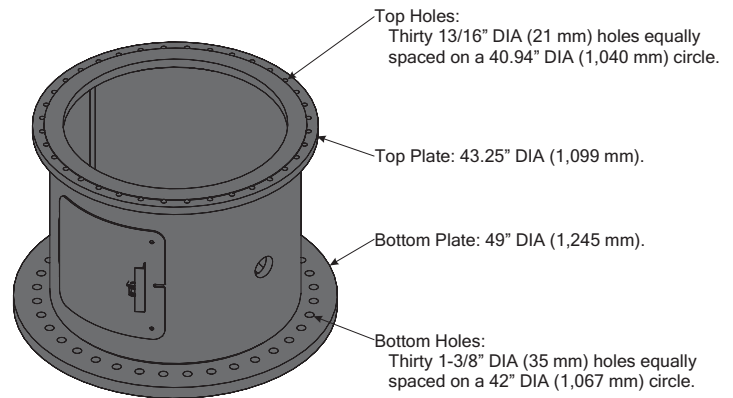
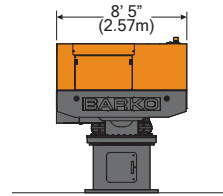
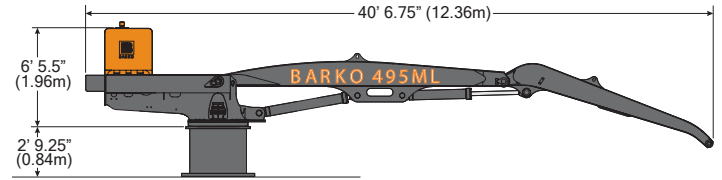

**BARKO HYDRAULICS, LLC**

One Banks Avenue | Superior, WI 54880 | Ph: 715.392.5641 | Fx: 715.392.3931 | www.barko.com